



29 rue du 14 juillet
67980 - Hangenbieten
FRANCE
Tel. : +33 3 88 48 53 00
www.soframe.com

DEFENSE



© SOFRAME - 042024 - D19022A - All rights reserved. This document is the exclusive property of our company. All descriptions, specifications and characteristics are given for information only and do not represent a commitment of any kind. Non contractual photos.

CRV

Combat Recovery Vehicle



DEFENSE

EN



Technical characteristics

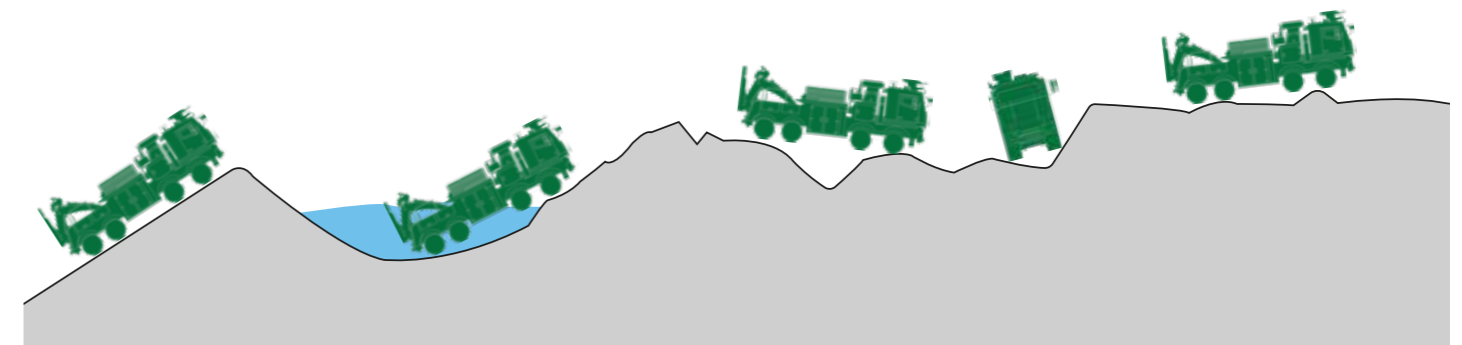
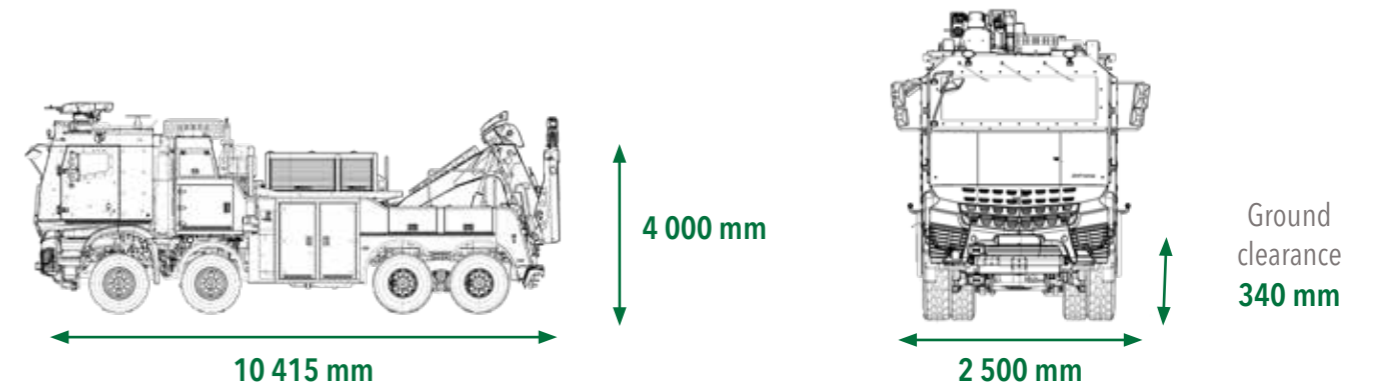

Slope
60 %

Fording
700 mm

Trench
700 mm

Side Slope
30 %

Step
400 mm

The **CRV** is a vehicle equipped with a **heavy towing system** used for the evacuation or extraction of broken-down wheeled vehicles.

Thanks to its **versatility** and **extended driving capabilities**, it can operate on all types of terrains.

The vehicle has a **STANAG-certified** armoured cab to protect its crew against the threats of the modern battlefield, enabling it to approach close to combat units.

The configuration of its tool **rack enables it to carry out repairs under all sorts of difficult conditions**. The crew has the tools required for the most complex support operations to hand in a setup adapted to the missions.

High ballistic and mine protection

Maximum speed: 90 km/h

Gearbox: Automatic

Range: 800 km

Engine: 350 kW (476 hp)

Turning radius: 13.5 m

Self-haulage: 10 t at 60 m

Crew: 3 people

The CRV is a reliable, robust, powerful, fast, modular military logistics and support vehicle.